

DIMENSIONI INGOMBRO TRASPORTO
TRANSPORT EXTERNAL DIMENSIONS

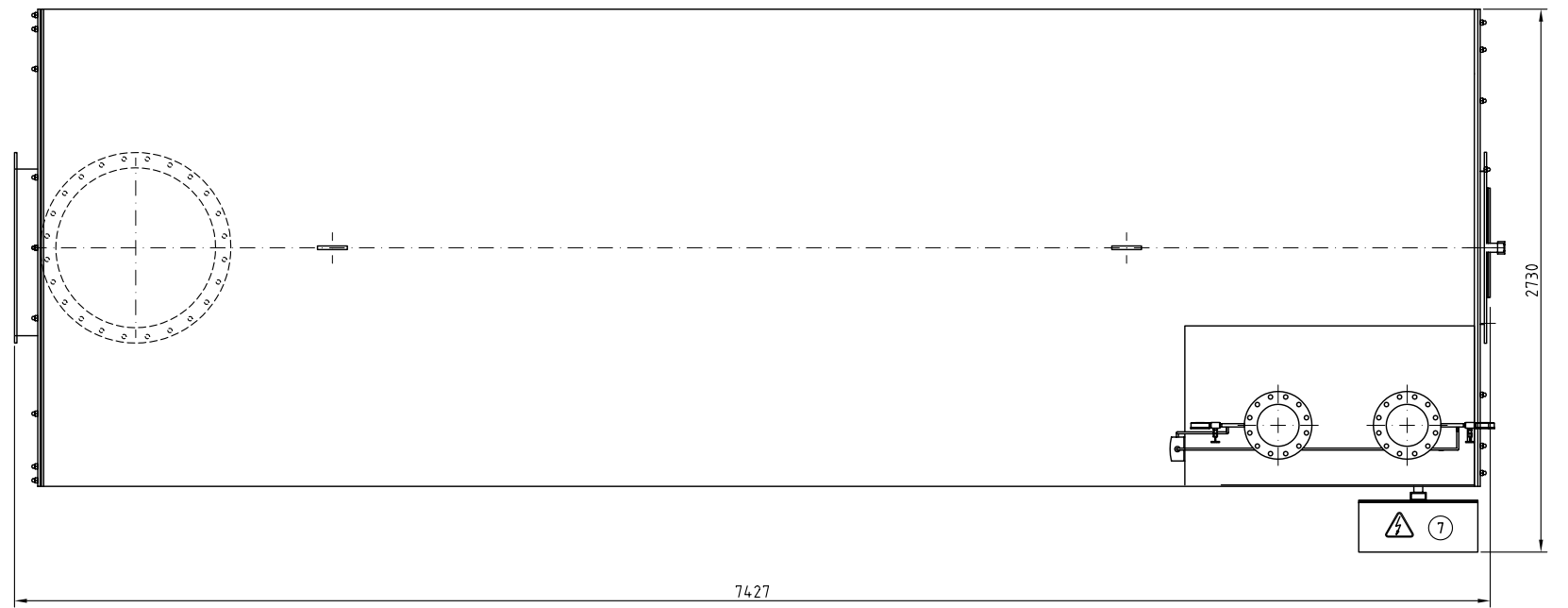

| | |
|------------------------------|----------|
| A | 7430 mm |
| A1 | 9250 mm |
| B | 2950 mm |
| C | 2750 mm |
| PESO A VUOTO EMPTY WEIGHT | 13500 Kg |

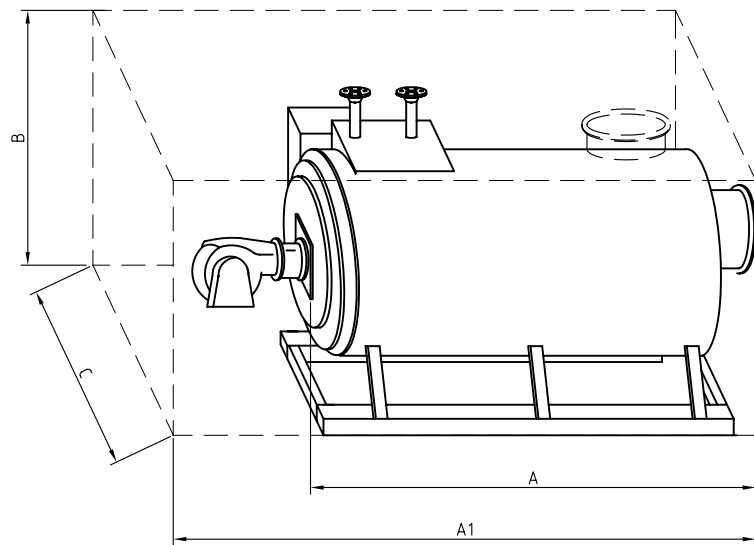
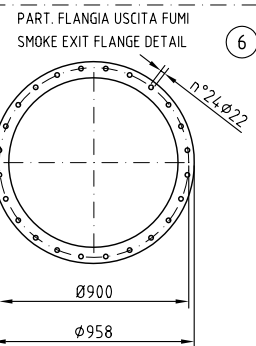

| POS. | NR. | DESCRIZIONE | DESCRIPTION | NOTE |
|------|-----|-----------------------------------|------------------------------|--|
| 7 | 1 | QUADRO ELETTRICO | CONTROL PANNEL | |
| 6 | 1 | USCITA FUMI | SMOKE EXIT | DIN86044 DN800 |
| 5 | 1 | PRESSOSTATO DIFERENZIALE | DIFFERENTIAL PRESSURE SWITCH | |
| 4 | 2 | MANOMETRO | PRESSURE INDICATOR | |
| 3 | 1 | USCITA OLIO | OIL OUTLET | DN200 PN16 |
| 2 | 1 | INGRESSO OLIO | OIL INLET | DN200 PN16 |
| 1 | 1 | CALDAIA AD OLIO DIATERMICO TH5000 | TH5000 THERMAL OIL HEATER | EMPTY WEIGHT: 13500 Kg OIL CONTENTS: 3127 l |

| REV. | DATA | MODIFICHE | DIS. | APP. |
|------|----------|--------------------|--------|------|
| 3 | 20/12/06 | Trasporto | F.S. | P.A. |
| 2 | 17/03/06 | Revisione generale | M.M. | C.D. |
| 1 | 14/03/06 | Revisione generale | D.M.A. | C.D. |

Viale dei Caduti, 3
25030 CASTELMELLA (BS)
Tel. (030) 2681541 r.a
Fax (030) 2680910

GARIONI NAVAL

*DIMENSIONI DI INGOMBRO
EXTERNAL DIMENSIONS
TH 6000*

| | | | | | |
|-----------------------|--|-------------------|--|----------------|--------------------|
| DISEGNATO S.F. | | APPROVATO C.D. | | SCALA 1:25 | DATA 09/05/2005 |
| COMMESSA | | | | REVISIONE 3 | |
| SOSTITUISCE IL | | | | SOSTITUITO DAL | |
| DISEGNO N. 05-0205 | | | | | |

QUESTO DISEGNO E' DI NOSTRA ESCLUSIVA PROPRIETA' E' VIETATO A TERMINI DI LEGGE RIPRODURLO O DIVULGARLO A TERZI SENZA LA NOSTRA AUTORIZZAZIONE